



TELECOM INFRA PROJECT

Creating an ecosystem for vRANs supporting non-ideal fronthaul

Table of Contents

Introduction	3
Project Overview	4
Architecture	6
Split Architecture.....	6
DOWNLINK.....	6
UPLINK.....	7
Open fronthaul interface	9
Fronthaul agnostic vRAN.....	10
Benchmarking performance.....	10
Centralized Scheduler.....	10
Compression	10
Synchronization	11
Operator-sponsored Use Cases	12
CableLabs-sponsored.....	12
TIM-sponsored	13
BT-sponsored.....	13
Bharti Airtel-sponsored.....	14
The Common Thread.....	14
Lab Testing Summary	16
Route to commercialization	20
Contact Info	22
Abbreviations	22

Introduction

The Telecom Infra Project (TIP) is an engineering-focused initiative driven by operators, suppliers, developers, integrators, and start-ups to disaggregate the traditional network deployment approach. The collective aim of the TIP community is to collaborate on new technologies, examine new business approaches and spur new investments in the telecom space.

The vRAN Fronthaul project group, formed in 2017, is aimed at developing a vRAN ecosystem that can be deployed over a range of transport links that are non-ideal. This whitepaper provides an overview of this project, being published at a critical time (early 2018) when the project activities move on from basic technology proof-of-concepts, to multi-vendor commercial-grade solution development, taking place across four TIP Community Labs.

First, we provide an overview of the vRAN project and its scope. This is followed by a more detailed discussion about the vRAN network architecture, highlighting some of the design considerations of the open fronthaul interface. The vRAN development focuses on operator use cases, with the activities running in TIP Community Labs hosted by the use case sponsors. A summary of the six vRAN use cases driving this TIP Community Lab activity is provided, followed by some early results that demonstrate the viability of the vRAN architecture to work over non-ideal fronthaul. Finally, a project timeline describes how we intend to move from early proof-of-concept, to multi-vendor solutions, to trials and commercial deployment.

Project Overview

A virtualized RAN (vRAN) can offer a range of benefits for both the end user and the telecoms industry as a whole. When deploying a vRAN solution, an operator has critical decisions to make, such as where to “split” the RAN architecture. A split that has more centralized processing of the current baseband protocol stack offers better performance (improved inter-site coordination and pooling gains for the centralized baseband processing), while the requirements on fronthaul (the transport connecting the remote radio unit (RRU) and the virtualized baseband unit (vBBU)) become tougher to meet as the split gets lower in the baseband protocol stack.

The TIP vRAN project is developing an ecosystem that allows for a wide range of vendors to provide innovative, best of breed RRUs and vBBUs for a diverse set of deployment scenarios. The scenarios can be managed and dynamically reconfigured using a virtualized infrastructure with standardized data models.

The standardization and specification of the vBBU and RRU interfaces (or the fronthaul interface) is currently under investigation in many organizations such as 3GPP, IEEE 1914, eCPRI, xRAN, etc.

The focus of the TIP vRAN Fronthaul group is to achieve a commercially viable ecosystem for vRANs where the transmission between the vBBU and the RRU can work over non-ideal (lower bandwidth and/or higher latency compared to CPRI) fronthaul.

The main aims of the project are as follows:

- Focus on operator use cases – To enable the smoothest routes to market, the project activities will be based on operator-sponsored use cases. Each sponsoring operator will host lab activities in their own TIP Community Lab. The developments, optimizations and assessments within that lab will focus on that operator’s use cases.
- Non-ideal fronthaul – Producing a vRAN solution that can cope with non-ideal transport, enables an operator to exploit its existing infrastructure, and enables vRAN solutions to apply to a wider range of use cases. Ideal and non-ideal backhaul has been defined by 3GPP (36.932). This can be summarized as ideal backhaul having one-way latency under 2.5us and throughput up to 10Gbps. Non-ideal varies over a wide range of capabilities with latency typically between 2-60ms and throughput from 10Mbps up to 10Gbps.
- Optimization and Compression – To enable a low layer split to function over a range of non-ideal fronthaul, new optimization and compression techniques will be integrated into the LTE radio stack
- Open interfaces – To enable a competitive ecosystem, open interfaces are required to ensure interoperability between RRUs and vBBUs which come from different vendors.

- Software and Hardware platform – By implementing the radio stack in software, the network can become more flexible and reconfigurable. This project will not only develop the software of vRAN, but also the hardware platform to support it.
- Low-cost Remote Radio Units (RRU) – This can be achieved by developing products that can apply to a wider market. Also, by centralizing some of the radio functionality, it may be possible to make cost savings by reduced functionality in the RRU.

Open interfaces are crucial for a multi-vendor deployment. This project will start by defining requirements for a low layer split, allowing the hardware platform and use case development to start now, while acknowledging and trying to influence and drive other industry activities in this area. Our objective is to avoid fragmentation while we will work towards alignment and leverage the benefit of a reconfigurable network. The interface used for the low layer split could be enhanced later in the activity, to improve alignment with other alternatives that may emerge in the industry.

Within the project, a proof-of-concept has already been produced in three TIP Community Labs. These demonstrate the suitability of the fronthaul interface to function over non-ideal transport. The focus is now on implementing this interface into multi-vendor solutions with commercially-ready software and hardware, while optimizing it for operator-specific use cases.

Key operator requirements include:

1. Develop a vBBU – RRU interface that enables interoperability
2. Develop an open data model approach that enables O&M interoperability among diverse RAN implementations including support for multiple intra PHY split options.
3. The design should minimize the optionality in the traffic and management plane to meet key requirements and simplify development and interoperability.
4. The interface should reduce bandwidth utilization relative to CPRI and scale as a function of radio throughput.
5. The interface should not depend on a specific transport layer-1 or layer-2 implementation and shall be deployable over a variety of links and fronthaul transport networks, including Ethernet and packet-switched networks based on Internet Protocol (IP).
6. Standards based vBBU – RRU synchronization solutions should be addressed.
7. Develop a vBBU – RRU interface that support both 4G and 5G-NR, as well as advanced features such as live migration, carrier aggregation, licensed-assisted access, Coordinated Multi-Point (CoMP), etc.

Architecture

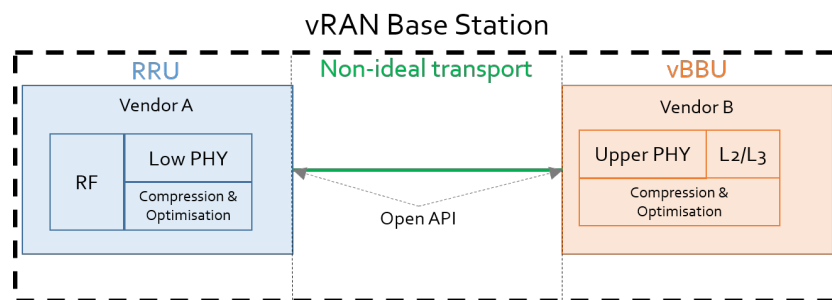

Figure 1 - TIP vRAN base station architecture

The base station architecture adopted for this project is shown in Figure 1. The full radio stack is split at the physical layer. The lower physical layer is placed in the RRU while the upper physical layer along with layer 2 and 3, are placed in the vBBU. By the use of an open interface, the RRU and vBBU can be provided by different vendors. Compression and optimization features will be required in both the RRU and vBBU to enable functionality over non-ideal fronthaul. The project includes several RRU and vBBU vendors, so each TIP Community Lab will have one or two RRU vendors, plus another vendor to build the vBBU.

Since the inception of the vRAN Working Group in the spring of 2017, several requirements have been identified as key for a successful architecture and fronthaul interface, both from a technical perspective, as well as to ensure widespread adoption and a wide and diverse ecosystem.

Split Architecture

DOWNLINK

The figure below indicates a general transmission chain along with a few “injection points” that are potential functional split candidates. Firstly, regardless of the injection point chosen, encoding is performed at the vBBU.

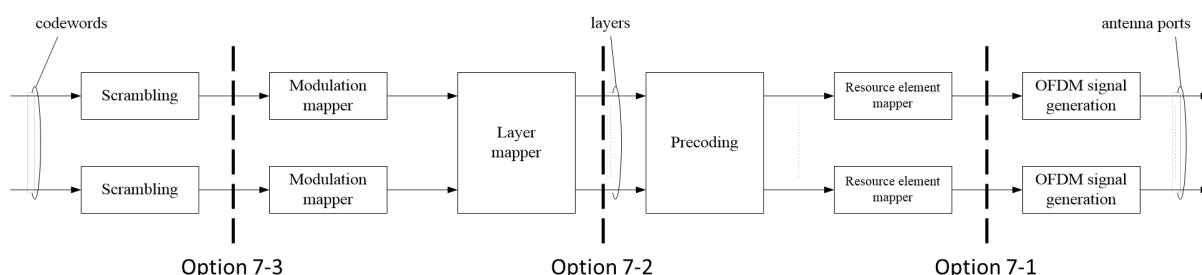

Figure 2 - Downlink Split Injection Points

Many of the downlink physical signals of both 4G and 5G are efficiently represented as integer indexes within finite constellations. Given this signal representation, one split supported by the vRAN fronthaul interface, known as “7-3” and indicated in Figure 2, is typically the most beneficial from a fronthaul utilization perspective. When using a 7-3 split, modulation mapping, layer mapping, precoding, resource element mapping, and OFDM signal generation are performed at the RRU side. Hence, a downlink protocol unit transferred over the fronthaul includes all the dynamic parameters needed at the RRU to perform these operations e.g. modulation orders, spatial scheme and associated beam weights.

Despite the compression benefits of a split 7-3, certain signals may not belong to fixed constellations of limited size, and may thus be better represented as complex samples, therefore using a split 7-2 or 7-1. An example where a lower split is better suited is distributed downlink MIMO. Vendors may want to deploy several distributed RRUs controlled by the same vBBU and enable distributed coherent joint transmission. In this flavor of CoMP the same data is transmitted across multiple distributed transmission points (i.e., RRUs), with suitable beamforming weights so that multiple spatial layers are multiplexed on the same time-frequency resources (i.e., tones). In such a case each RRU could be used to transmit more spatial layers than the number of antennas it has on board, as spatial multiplexing is achieved across physically separated points.

In summary, downlink protocol units (DPUs) are delivered to the RRU over the fronthaul, each DPU including zero or more records with each record describing the signal representation (constellation, complex samples), spatial processing (layer mapping and precoding), and resources where the signals maps to. Note that a split 7-1 is covered as a special case, whenever the resource field indicates “all tones”.

UPLINK

The figure below indicates a general uplink chain along with a few “extraction points” that are candidate functional splits for uplink.

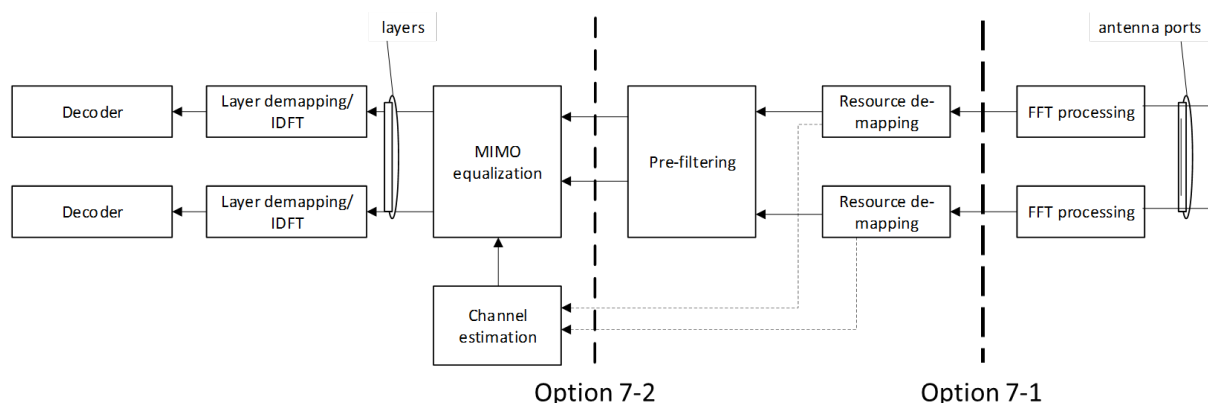

Figure 3 - Uplink Split Extraction Point

The split supported by the interface with the most processing at the RRU side, also known as 7-2, requires the RRU to perform some form of spatial processing or spatial “compression”, where the signals from the receive antennas are processed to obtain per-spatial-layer streams. Transferring signals per layer, rather than per antenna, can be beneficial from a fronthaul compression perspective, whenever the number of spatial layers is much smaller than the number of receive antennas, which is typical in massive MIMO use cases. The type of spatial processing needs to be dynamically indicated to the RRU, and can include simple processing such as antenna selection, or more involved ones such as linear equalization, with equalizer’s weights being selected by the vRAN and provided to the RRU.

In one example of the per-channel representation, there could be two uplink data signals (PUSCH, in 3GPP terminology) with significantly different coding and modulation formats, spatial characteristics, or resource allocation, both received by the baseband in the same subframe. The RRU may receive a request to perform different processing and compression for the two signals, for instance, different spatial processing. Similar to what may happen in downlink, for uplink it could be beneficial to offer uplink signal extraction before spatial processing, via dynamic signalling to the RRU. A simple way to describe resources, known as a “tone map”, has been designed as a compromise between flexible resource allocations and complexity in the description of said resources, and is used to identify resources over which each physical signal maps to.

Therefore, the protocol API needs to provide a way to convey this information in the downstream direction of the fronthaul link. Specifically, once uplink scheduling decisions for a given future time interval “n” are finalized in the vBBU, scheduling information is provided to the fronthaul interface (in the vBBU L1), that encodes and embeds it into a downstream protocol unit that is sent to the RRU, as depicted in the Figure 4. Note that, in radio technologies characterized by collision-avoidance scheduling, such as 4G and 5G-NR, the scheduling entity (the vBBU in this case) needs to provide uplink scheduling decisions to the mobile terminal in advance, and such scheduling decisions are conveyed in suitable downlink control information. In particular, with reference to the figure, the DL time interval “n” may need to convey uplink scheduling information for a (future) uplink time interval “n+k”, which explains why unicast uplink scheduling for “n+k” must happen at the same time as DL scheduling for “n”.

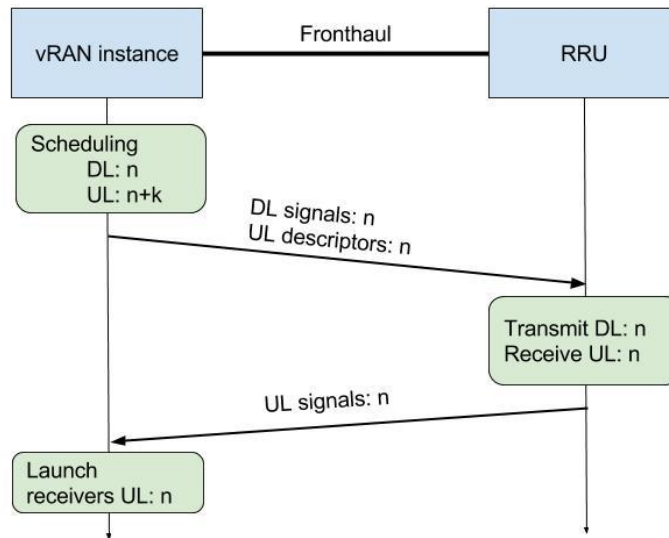

Figure 4 - Fronthaul Tone Map Signalling

The RRU needs to receive the protocol units that describe the upcoming uplink signals before the uplink radio samples are actually received from the antennas, so that the RRU knows the type of processing and compression of each physical signal in advance. Though it may seem that this process increases the overall latency, in reality, the 3GPP RATs are based upon centralized contention-free multi-access, the scheduling decisions for the return (uplink) channel have to be taken in advance anyway, because they have to be delivered to the mobile terminals.

Open fronthaul interface

While the project has been initially focussed on 4G, a design requirement of the interface is to be "5G-ready". The fronthaul interface could be seen as an Application Programming Interface (API) that a baseband implementation (either virtual or traditional) may invoke to efficiently transfer structured radio signals from/to the RRU.

Throughout the development of the interface, a trade-off between generality and complexity of the interface was agreed upon within the group, where certain features (such as the option of transferring signals as time-domain samples) were postponed to a later release.

The breadth and diversity of the ecosystem supporting the architecture and open interface is a key to commercial success beyond trials. Often a vendor's value proposition relies on "premium features" as differentiating factors against competitors, as such the interface has been designed to support these. Some examples of vendor designed premium features supported by the interface include proprietary scheduling algorithms, multi-user MIMO and

coordinated multi-point schemes, and advanced selection of spatial beams across co-scheduled signals within the same subframe.

Lastly, a key benefit of the considered functional split is its promise of total cost of ownership (TCO) reduction stemming from unbundling of end-to-end closed products, which enables operators to pick-and-choose network elements from different vendors. For this reason, interoperability between different vendors is of paramount importance to allow multi-vendor solutions within the same deployment.

An important aspect of multi-vendor interoperability is a well-defined “operation, administration, and maintenance” (OA&M) protocol, which is part of the planned work.

Fronthaul agnostic vRAN

In order to support a variety of ideal and non-ideal transport links as fronthaul, the fronthaul protocol must be agnostic to the physical and link layer of the transport, contrary to other interfaces which directly operate on the layer 1 or layer 2 of the transport link. Hence, a layer 3 packet-switched interface was chosen, to ensure seamless deployment over a range of physical media and link layer protocols.

Benchmarking performance

While the interface needs to support non-ideal links, it was also deemed necessary to produce ideal performance when an ideal fronthaul transport is used. That is, a transport whose latency and jitter can be considered as negligible. If the fronthaul transport can support a more traditional “split-8” architecture, based on the CPRI protocol, products deployed with this new interface shall be able to achieve the same performance.

Centralized Scheduler

The choice of a “low-PHY” functional split between vBBU and RRU brings both benefits and challenges. One of the key benefits is the potential centralization of all MAC functionalities, as well as a significant part of the PHY. vBBU implementations could leverage these centralized functions to enable advanced features such as coordinated multi-point (CoMP), for both downlink and uplink, including distributed massive MIMO transmission and reception across physically separated RRUs. These advanced techniques are expected to bring significant performance benefits in dense or heterogeneous networks, dominated by inter-cell interference.

Compression

Fronthaul bandwidth compression is another key aspect for a successful interface. While the benefits of compression are obvious in non-ideal fronthaul scenarios, they are remarkable in ideal scenarios as well. Regular uncompressed transfer of time-domain baseband samples (known as “split 8” in 3GPP terminology) requires fronthaul bandwidths so large that scaling to more complex network deployments (with multiple antennas, carriers, and large radio bandwidths) can be challenging even with a dedicated, fiber-grade transport network. In addition, a compression scheme that varies with user plane load, allowing low fronthaul

throughput in case of an unloaded or lightly loaded RRU, offers benefits in resource pooling across multiple RRUs and reduced fronthaul power consumption.

Compared to a “split 8” protocol, a split in the family of “7” offers more opportunities for compression. Specifically, a split 7 solution can achieve significant compression and realize load dependency by transferring frequency-domain signals from a 4G OFDM/SC-FDMA system and selecting to transmit only those tones used to carry information in any given symbol.

Furthermore, 3GPP LTE, as well as other radio access technologies, define “physical channels” with different characteristics, e.g., coding, spatial processing, or constellation mapping. A common functional split across all physical signals, despite their widely different characteristics and processing chains, may limit the benefits of a “split-7” architecture. Instead, a per-physical-channel representation over the fronthaul exhibits several benefits, as discussed in previous sections.

Synchronization

Synchronization to a common time reference is needed to enable integration into an existing RAN network and to support advanced features such as CoMP. To enable synchronization between the vBBU and the RRU, the fronthaul interface will contain a synchronization field, or timestamp, which will have a required precision. Sub-frame alignment is required across multiple RRUs for the initial FDD use cases. While the protocol will support this signaling, the method used to achieve the required clock synchronization will not be specified. Example solutions which would achieve sub-frame alignment that implementers could choose from include GPS, IEEE-1588, or macro network listening.

Requirements for synchronization may be specified by sponsoring operators within each TIP Community Lab based on use case needs.

Operator-sponsored Use Cases

The vRAN Fronthaul project group has attracted a diverse set of operators who have taken to heart the TIP directive to reimagine the traditional approach to building and deploying telecom network infrastructure. In this case, the operators have reimaged what IP link types can be used for vRAN fronthaul. Table 1 shows the current set of 6 use cases along with the sponsoring operator, fronthaul transport link, and the target cell size / density.







Use Case	Sponsor	Transport	Cellsize and Density
Small Cell vRAN		DOCSIS	High density indoor femto, or outdoor small cells
vRAN Cluster in Hetnet		PON/DWDM/microwave	Medium to high density small cells in hetnet
Street Coverage		G. Fast	Medium density pico/macro
Campus		Managed Ethernet	High density micro/femto
Temporary Coverage		Cellular in-band/microwave	Low density pico
Macro Coverage		Microwave	Medium/high density macro sites

Table 1 - vRAN Fronthaul Use Cases and Sponsors

The development of a fronthaul protocol capable of handling this diverse set of IP links allows for the benefits of cRAN/vRAN (e.g., resource pooling, ease of deployment, scalability, favorable economics) to be applied to a new class of deployments.

CableLabs-sponsored

1 - Small Cell vRAN over DOCSIS

CableLabs' 59 cable and mobile network operators have extensive hybrid-fiber-coax (HFC) network coverage around the globe. This use case will focus on fronthaul compression and latency tolerance to allow vRAN deployment over the existing cable HFC and DOCSIS network footprint. Deployment targets include indoor femto cells in residential scenarios as well as dense small cells in urban areas.

TIM-sponsored

2 - vRAN HetNets over PON and its Evolution

The TIM use case is focused on the road to 5G and massive MIMO deployments. Fiber will become an increasingly relied upon asset as networks evolve: small cells can be connected using the same broadband access technologies and infrastructure used for residential or business users. The TIM use case targets efficient use of fiber where compression is the first priority to ensure long term exploitation of existing fiber assets and their evolution (i.e. PON and, looking at the wider bandwidths envisaged for 5G, next generation PON technologies). In addition to compression, latency tolerance will provide additional robustness in scenarios where baseband units are installed as far away as the metro central office and connected to the antennas through a shared packet network.

BT-sponsored

BT is responsible for delivering fixed and mobile services across a wide array of deployment scenarios. The economics and/or feasibility of fiber installations to support temporary services (e.g., emergency or event scenarios), dense urban street coverage in-fill, and campus scenarios are challenging. The BT use cases will focus on a fronthaul protocol that is flexible enough in compression and latency tolerance to be used across managed Ethernet, G.Fast, microwave, or in-band cellular. These use cases also consider multi-operator/neutral host capabilities. This can further improve the business case for a number of deployment scenarios.

3 - Pico/Macro Street Coverage over G.Fast

This use case focuses on providing street level coverage. RRUs could be deployed on drop poles and existing copper infrastructure then used as the fronthaul connection to vBBUs, which may be located at local exchanges. In particular G.Fast technology is seen as being a suitable candidate for vRAN fronthaul.

4 - Campus Deployment over Managed Ethernet

A campus environment that has existing infrastructure (e.g. Managed Ethernet) is a very exciting proposition for deploying a high capacity small cell network. The vRAN solution would use the existing managed Ethernet infrastructure as fronthaul between RRUs and vBBUs. The RRUs may be a mix of indoor and outdoor cells for coverage and capacity purposes.

5 - Temporary Coverage over Cellular In-band/Microwave

One of the main characteristics of this use case is that the cell, or a cluster of cells, can be deployed in a short timescale to provide temporary coverage. This is applicable to both emergency scenarios where there is no mobile coverage or where mobile coverage is temporarily unavailable. This is also applicable to situations where temporary coverage/capacity increases are required for special events.

The most appropriate fronthaul depends on what is available in the area, so a range of options can be considered. The most likely candidates are microwave links and in-band cellular. Although the focus in this use case is temporary coverage, the developed solutions can also apply to rural coverage and remote areas where the deployment would not be temporary.

Bharti Airtel-sponsored

6 - Macro Coverage over Microwave

Airtel, the leading operator in India, is expanding its 4G footprint to cover a wider population in towns and villages across India. The Airtel use case will evaluate the feasibility of using centralized vRAN over non-ideal fronthaul to reduce TCO and improve user experience. Due to limited 4G spectrum, this use case will also study the scalability when supporting high subscriber densities. Finally, this use case will focus on compression and latency tolerance to enable vRAN deployments over multi-hop microwave links designed to maximize the reach of the Airtel network.

The Common Thread

The goal of each TIP Community Lab is to create a solution using the open API that is interoperable with the other use cases while also addressing any requirements that are unique to the specific use case. To ensure each lab is working towards the same interoperability definition, the requirements in Table 2 have been agreed upon in the vRAN Fronthaul project for interoperability testing.

Fronthaul Condition	Throughput	Latency	Loss
"Ideal"	10x DL BW in MHz e.g. 200Mbps for 20 MHz	<1ms	<0.01%
	12x UL BW in MHz e.g. 240 Mbps for 20 MHz		
"Non-Ideal"	5x DL BW in MHz e.g. 100 Mbps for 20 MHz	30 ms	0.1%
	6x UL BW in MHz e.g. 100 Mbps for 20 MHz		

Table 2 - Baseline interoperability requirements

The IP links identified in the vRAN Fronthaul use cases span every combination of high to low throughput, latency, and loss as shown in Table 3.

Fronthaul Type	Throughput	Latency	Loss	PDV
PON and its evolution	Medium to High	Low	Low	Low
G.Fast	Medium	Low	Low	Low
Managed Ethernet	Medium	Low	Low	Low
DOCSIS	Medium	High	Low	Medium
Microwave	Medium to Low	High (multiple hops) to Low (single hop)	Medium	Medium

Table 3 – Comparison of fronthaul options

The interoperability requirement ensures the open API finds common implementations across products. By ensuring interoperability among use cases, the resulting products will have a wider addressable market. While each use case is sponsored by an operator, these use cases can apply to many other operators. Also, the flexible nature of the developed vRAN solutions should enable them to be applied to a wider range of use cases.

Lab Testing Summary

“Phase 0” testing has been completed in multiple TIP Community Lab locations. Initial testing has confirmed basic functionality and provided encouraging results using a single vendor solution over multiple non-ideal fronthaul links.

One such test bed is installed in the CableLabs Louisville, Colorado USA headquarters. Testing at this facility has been conducted over DOCSIS network fronthaul i.e. the link between the Cable Modem Termination System (CMTS) and the Cable Modem. The DOCSIS network configuration employs DOCSIS 3.0 compliant equipment offering peak fronthaul data rates of 500 Mbps downlink and 200 Mbps uplink. Figure 5 shows the network topology for the phase 0 testing at CableLabs.

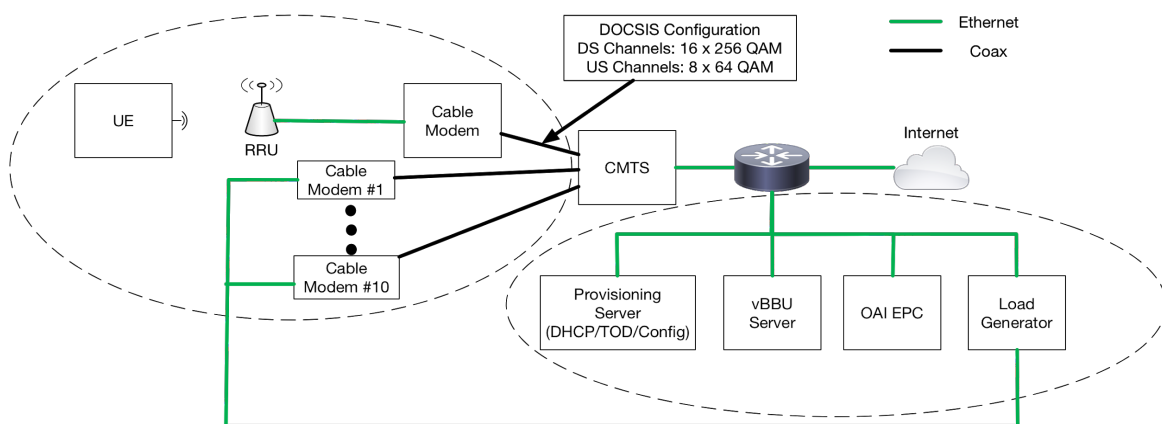

Figure 5 - CableLabs Phase 0 Network Topology

Table 4 shows performance data for testing of a 20 MHz Band 7 cell with 2x2 MIMO, Category 4 UE, and no congestion on the fronthaul link.

	Peak		Minimum	
	LTE User Plane	Fronthaul Link	LTE User Plane	Fronthaul Link
Downlink Throughput	150 Mbps	180 Mbps	0 Mbps	5 Mbps
Uplink Throughput	50 Mbps	200 Mbps	0 Mbps	~1 Mbps
RTT Latency	n/a	<= 30ms	n/a	n/a

Table 4 - TIP vRAN Fronthaul Performance (Example 20 MHz 2x2 Cell)

In addition to peak performance testing of the fronthaul link and LTE user plane, CableLabs has also performed basic congestion testing. Again here, initial results using the phase 0 solution indicate the system is able to detect and adapt to restricted resources on the fronthaul link.

Specifically, CableLabs has performed static fronthaul rate limiting (e.g. limiting the DOCSIS network throughput to 50 Mbps in both DL and UL) and more dynamic, congestion related resource limiting by flooding competing cable modem users with traffic. In both cases, the vRAN fronthaul system was able to adapt, keep the cell active, only restricting LTE user plane throughput as needed to constrain the offered fronthaul load.

Importantly, as indicated in Table 4, the vRAN fronthaul phase 0 solution can adapt and tolerate a case where the DOCSIS network latency approaches 30ms on average. While this represents a somewhat extreme case for a properly managed network, it demonstrates the robust latency tolerance afforded by this vRAN fronthaul solution.

Figure 6 shows the lab setup at the CableLabs TIP Community Lab. As can be seen, the vBBU is running on a COTS tower server and commercially available DOCSIS cable modem and LTE UE are being used.

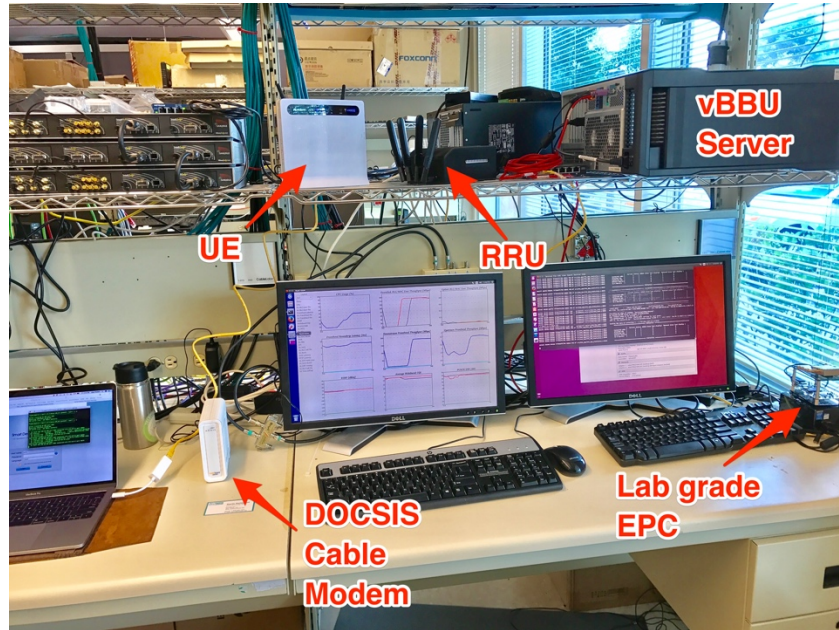

Figure 6 – CableLabs TIP Community Lab Phase 0 Setup

Another test bed is installed in Telecom Italia labs in Turin, Italy. In this case different tests have been performed introducing different impairments (in terms of latency, bandwidth limitations, jitter and packet loss) on the fronthaul of the phase 0 solution to check its robustness to work in non-ideal conditions. In particular, the netem tool has been used to introduce the impairments. For example, looking at the tests with bandwidth limitations, the system confirmed its ability to adapt to actual fronthaul conditions obtaining similar results to the CableLabs setup. Figure 7 shows the single user plane peak throughput performance vs available bandwidth over the fronthaul for a 20MHz 2x2 MIMO system, with both UDP and FTP full buffer traffic. The fronthaul available bandwidth has been reduced from 1 Gbps down to 3 Mbps. The system is still able to work even if with limited performance when the fronthaul bandwidth falls below a certain threshold.

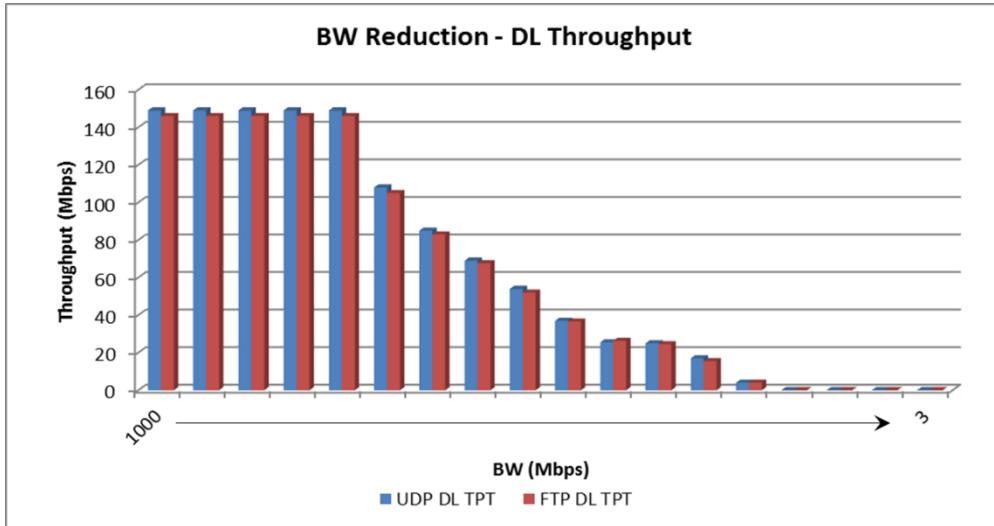

Figure 7 – TIP vRAN Fronthaul Performance (Example 20 MHz 2x2 Cell), air throughput vs fronthaul throughput.

Figure 8 shows the lab setup at the TIM TIP Community Lab. The vBBU is running on a COTS server and up to three RRUs can be connected to the system (in the picture they are switched off and put close each other).

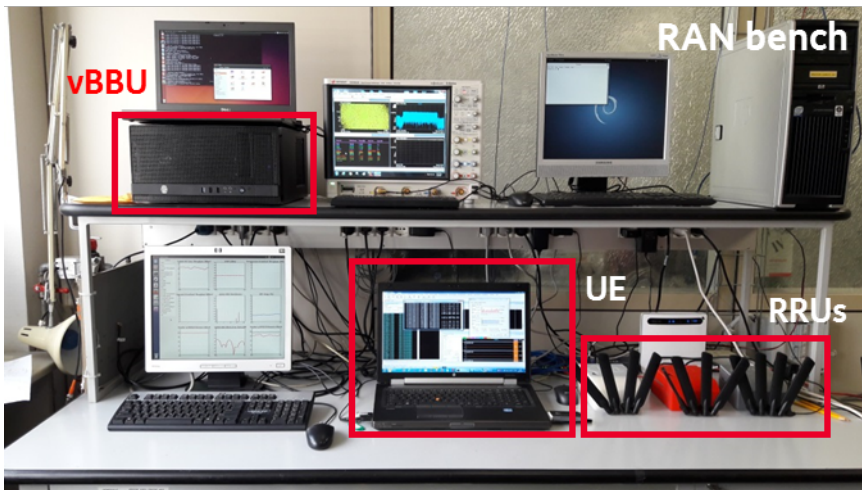

Figure 8 – Telecom Italia Community Lab Phase 0 Setup

Route to commercialization

In the early phase of TIP vRAN, the goal within TIP Community Labs is to verify functionality of vRAN components in a controlled environment using non-ideal transport. The architecture in phase 0 consists of one or two RRUs connecting directly into a vBBU hosted on a COTS compute facility. Early focus is to prove the technology and showcase that it can work over large distances (and thus latency) without compromising the operation, as that will help enable deployment over non-ideal transport.

Figure 9 below shows the timeline which the TIP vRAN fronthaul group is currently working to:

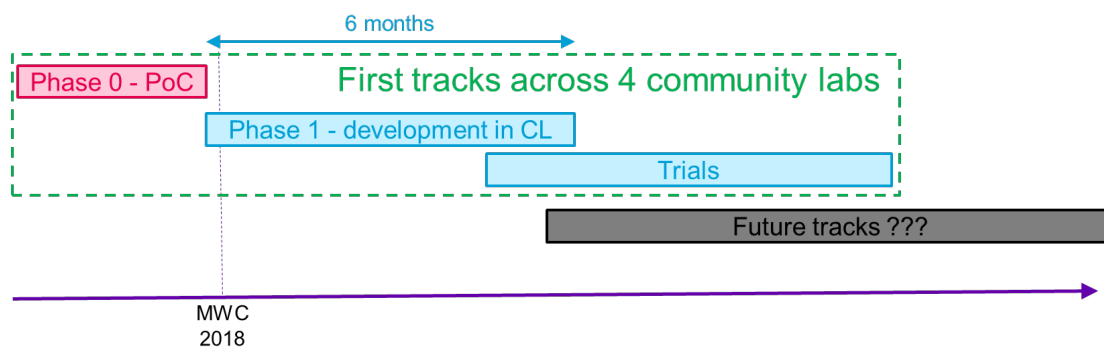

Figure 9 TIP vRAN Timeline

Within the TIP vRAN group, four TIP Community Labs are now established with vRAN solutions under test.

Exploring how vRAN may be deployed in a commercial setting, two key models which could arise include campus networks and as a deployment option for Small Cells and macro cell networks based on a C-RAN (Centralized and Cloud RAN) architecture.

1. In the campus network example, an estate of RRUs connect to a vBBU pool within the campus facility or rural location and offering added mobility and roaming ability over and above what can be achieved with other tools such as Wi-Fi. Campus deployments may be more suited to the first adoption of vRAN due to the somewhat self-contained environment in which they operate. Risk associated with adoption of a new technology is more limited in this domain.
2. Considering the deployment of vRAN in a wider mobile network catering for small Cells and macro cell architectures, the aim could be to reduce footprint at radio locations and achieve a centralized/cloud RAN offering improved scale/flexibility for the mobile operator. Such a model could offer the ability to flex the network in specific locations in sympathy with the user demand, overall reducing power and CAPEX through use of vBBU pooling and flexible connectivity to RRUs.

As TIP vRAN evolves and matures, a natural transition is expected, from proving the functionality, to performance optimization and development of the ecosystem, whilst also promoting competition in order to deliver the goals of the operator community with commercial solutions.

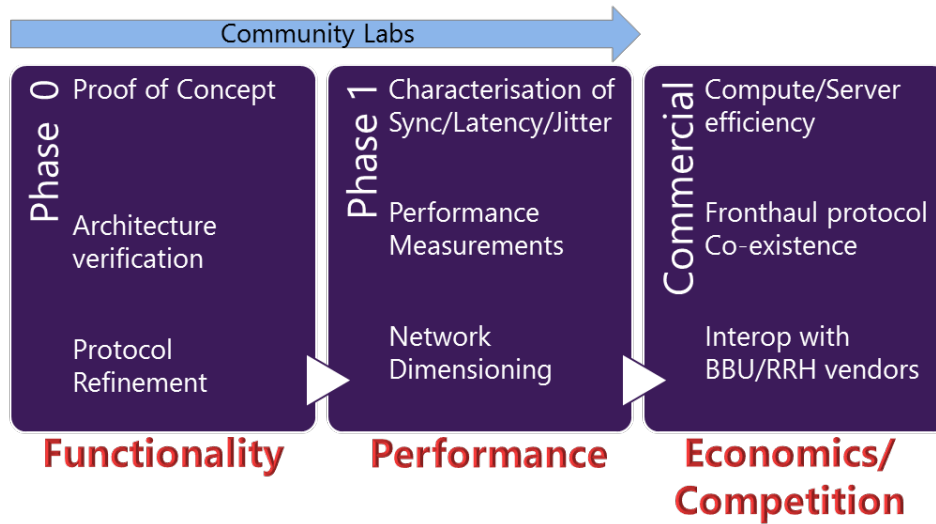

Figure 10 Focus Areas on Route to Commercialization

Contact Info

Website

<https://telecominfraproject.com>

Email

membership@telecominfraproject.com

Abbreviations

CoMP	Coordinated Multi-Point
CPRI	Common public radio interface
DPU	Downlink Protocol Unit
DOCSIS	Data Over Cable Service Interface Specification
EPC	Evolved packet core
HFC	Hybrid-Fiber-Coax
LAA	License assisted access
LLS	Low layer split
LTE	Long term evolution
MIMO	Multiple input multiple output
NR	New radio
PON	Passive Optical Network
PHY	Physical layer
RRU	Remote radio unit
TCO	Total Cost of Ownership
TIP	Telecom infra project
vBBU	Virtualized base band unit
vRAN	Virtualized Radio Access Network