

THE NEW KERN DSR SERIES OF FIRST ORDER ANALYTICAL PLOTTERS

Alain Chapuis, Jacob van den Berg
Kern & Co., Ltd
5000 Aarau
Switzerland
Commission II, ISPRS Kyoto, July 1988

ABSTRACT

The concepts involved in the design of the new Kern DSR series of Analytical Plotters are described and an overview is given of the new hardware and software options available.

1. INTRODUCTION

Analytical stereoplotters have rapidly assumed a leading role in modern photogrammetry. Kern has contributed to this development with a series of highly reliable and precise instruments. The DSRs, in production for more than eight years, have a good reputation for robustness, efficient operation and easy maintenance. By adding more hardware and software options to the range, Kern is continuing its policy of optimum price/performance ratios.

The concept of distributed processing, once unique to Kern, has become a de facto industry standard. Today, the advantages of allocating separate processors to handle realtime computations, thus relieving the central host computer from tedious routine work, are generally acknowledged.

Kern now introduces a new series of analytical plotters - the new DSR. There has been no need for major changes in architecture, but various technological improvements have been incorporated, coupled with an extended range of hardware and software options.

2. THE KERN HARDWARE PHILOSOPHY

Image superimposition, correlators and interactive graphic stations have become important components of analytical photogrammetric systems, increasing considerably their functionality and productivity. The possibility of adding such components to existing stations at a later date, greatly enhances the economic value of the previous investment. Continuity and compatibility are, therefore, important considerations in the design of modern photogrammetric hardware.

The concept of distributed processing and the modular architecture of the Kern DSR Analytical Plotters allow them to be linked with different computers, to suit the standard of performance required by the user. This is another important feature affecting the long-term value and economy of the Kern equipment.

Additional options

Graphic Hardcopy Output

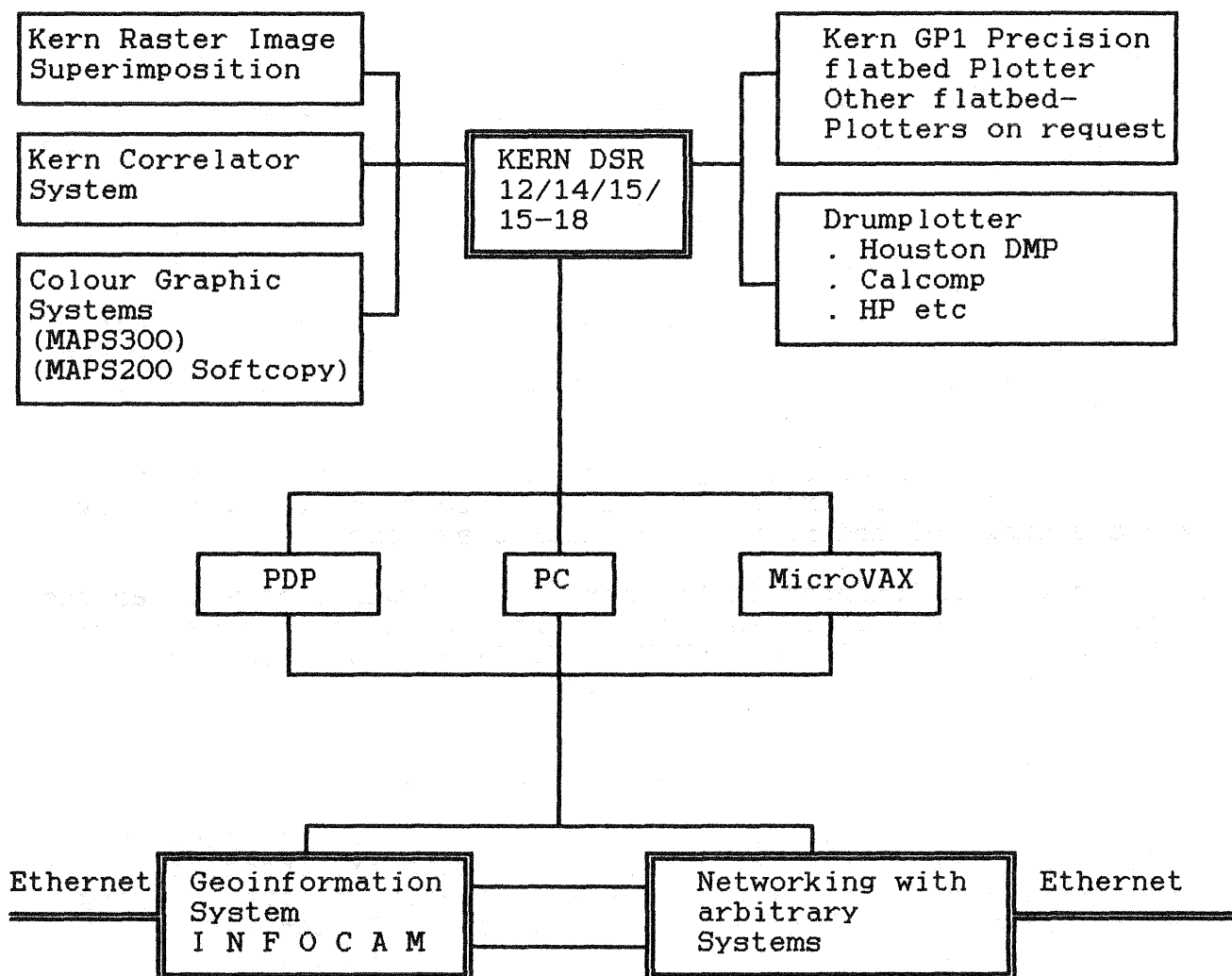

Fig.1 The concept of Kern Photogrammetric Hardware

3. THE KERN SOFTWARE PHILOSOPHY

For both user and manufacturer, Kern photogrammetric software represents an investment which may be built upon. The user invests not only in purchasing it, but equally in learning how to use it. This expenditure and experience should not be lost when adding to or upgrading the system. Not only must the software be as machine independent as possible, thus easy to transport and maintain as far as the manufacturer is concerned, but it must also be user friendly, with logical operational sequences, and easy to modify and add to from the customer's point of view. Effective tools are even provided allowing him to develop his own software.

The programming language PASCAL facilitates transparency and documentation of the programs, and it allows easy transportation to different operating systems. Standard PASCAL-compilers being available, the transportation of Kern software from the original DEC PDP and Micro 11 host computers to IBM-AT compatible PCs running under MS-DOS, or to the DEC MicroVAX running under VAX/VMS, has just involved simple compiling.

Similar to the hardware design, continuity, compatibility and modularity of the software are deciding factors for the productivity and economy of modern photogrammetric systems.

The concepts implemented in the Kern DSR software, as well as the various routines, libraries and options available, are described in the paper: "KERN PHOTOGRAMMETRIC SOFTWARE", by Luis Cogan and Dorothy Hunter (ISPRS Kyoto, July 1988).

4. NEW APPLICATIONS FOR ANALOGUE STEREOPLOTTERS

Worldwide, there still are some 10'000 analogue stereoplotters in daily use. Provided they are equipped with XYZ-encoders, these instruments are perfectly suited for up-to-date digital mapping. The well-proved Kern Digital Data Compilation System MAPS 200 has long been available for the Kern DSR analytical plotters, or for any analogue stereoplotters supported by computers of the DEC PDP or MicroVAX series. Since many photogrammetric organisations are using Personal Computers IBM-AT or compatibles, Kern now offers an alternative version of this software, for Personal Computers running under PC-DOS/MS-DOS, called "MAPS 200-PC-ANALOGUE".

For graphical PC-supported mapping, the Kern PG2 - or any other analogue stereoplotter - can be connected to automatic drawing-tables like the Kern GP1 or to a drum-plotter.

5. THE NEW DSR SERIES AND ITS CHARACTERISTICS

Pursuing its policy of versatility and optimum price/performance-ratios, Kern is presenting a new series of DSR Analytical Stereoplotters, supported by different host computers. According to the requirements of the options installed - suiting the actual needs

of the customer - such as image superimposition, correlators or interactive graphic stations, low-priced personal computers or powerful micro-computers are available. The successful system-architecture with distributed processing, fixed optics etc., remains the same for all versions. Should at any time the need arise for additional options and a more powerful computer, neither installation nor operation of the expanded system will be difficult. The operator uses the application software in exactly the same manner, whether the DSR is running with a PDP, a MicroVAX or a PC.

The main difference between the new models DSR-12, DSR-14 and DSR-15 is in the host computer and, consequently, in their capacity. On the DSR-15, all Hardware and Software options are available.

- THE KERN DSR-12

The DSR-12 uses DEC PDP equipment for computer support, with RT-11 single-user or TSX multi-user operating systems. Kern has been working with these popular and reliable computers for more than ten years; their operating systems provide ideal environments for the DSR software.

- THE KERN DSR-14

The DSR-14 works with Personal Computers as hosts. Since PCs are used in many photogrammetric organisations, it seems natural that they should be supporting analytical plotters too. Therefore, Kern now offers the new DSR-14 with either IBM-AT compatible or 80386-based PCs. Owing to PASCAL, transportation of the software from DEC PDP to PC has been easy, and the programs are running well in the familiar environment of PC-DOS/MS-DOS.

- THE KERN DSR-15

The host computer of the DSR-15 is a DEC MicroVAX or VAXstation. These excellent super-microcomputers and graphics workstations are perfectly suited to support one or more DSR-15s. Again, it has been easy to transport the DSR-software, using available PASCAL compilers.

Larger organisations may want to build up comprehensive networks, which can be extended to include photogrammetric workstations, editors, plotters, geoinformation systems, etc. This can be achieved efficiently by implementing DEC ETHERNET.

- THE KERN DSR 15-18

The DSR 15-18 is a DSR-15 equipped with larger plate-carriers for the format 25 x 50 cm used for LFC images. This special version, useful in applications for geological exploration, forest inventories etc., is only available with a MicroVAX hostcomputer.

6. NEW HARDWARE FEATURES

Apart from the wide range of host computers to choose from, the new DSR family incorporates many hardware features designed to make the instruments still more operator-friendly and effective to use.

- REDESIGNED STYLING

The new DSRs not only are aesthetically pleasing, but they fit perfectly into the modern ranges of integrated, modular office furniture.

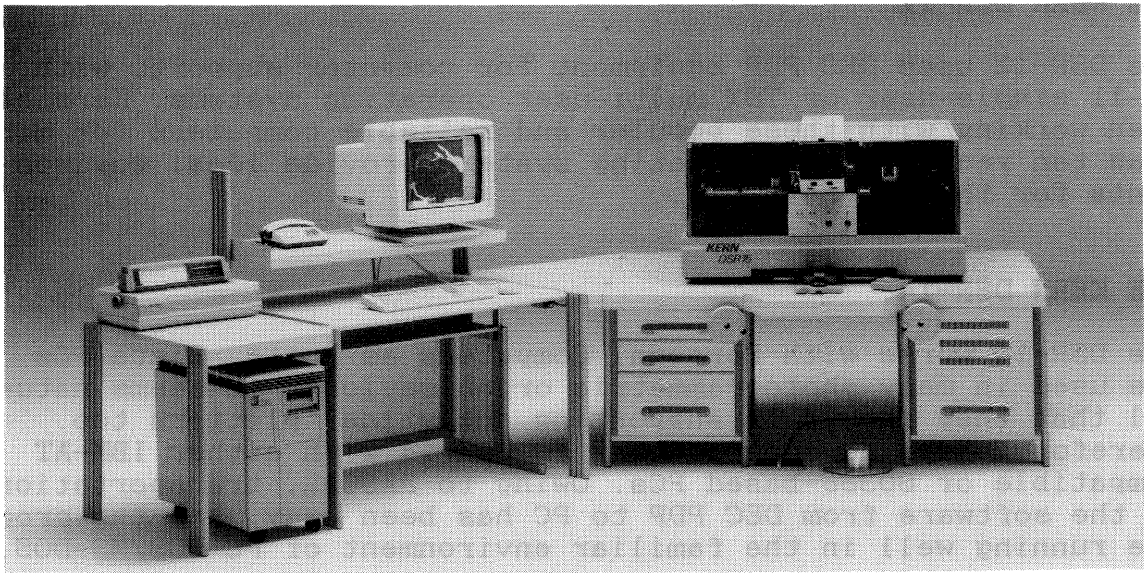

Fig.2 DSR-15 with MicroVAX and Softcopy GPX-Station

- IMPROVED OPTICS

The fixed optical system of the DSR has been significantly improved. A new type of glass ensures a still brighter image and chromatic aberration has been virtually eliminated. Zooming, with magnifications from 4.5 to 18x, can be applied separately in the two optical trains, permitting images of different scales to be viewed more comfortably. The fatigue free optics further enhances the operator's work environment.

Housings built around the optics reduce the entry of dust to a minimum. As an option, an innovative optical switch may be fitted, permitting binocular viewing of either image in addition to stereoscopic or orthoscopic viewing of the pair (i.e. LR/RL as well as LL/RR).

- D012 INSTRUCTION OCULAR

The new instruction ocular, particularly suitable for instruction and interpretation purposes, can be fitted as an option to all DSR-models.

- NEW OPERATOR PANEL

A touch-sensitive operator panel has been added to facilitate fast, error-free and ergonomic selection of feature codes, etc.

7. NEW HARDWARE AND SOFTWARE OPTIONS

In addition to various basic hardware configurations, including the choice of the host computer, and a wide range of application software, the customer may order major options which can considerably enhance the efficiency of his DSR system.

- KRISS (Kern Raster Image Superimposition System)

KRISS is an optional peripheral to the DSR-15, providing graphic overlays in real time motion through the viewing system of the instrument. It is a versatile tool to perform revisio-ning tasks of all kinds (e.g. cadastral surveys, forest inventories etc.) and for completeness checking at the data collection stage. Graphic images of very high geometric quality even permit stereo-superimposition.

System integration has been accomplished by expanding the distributed processing architecture, whereby the DSR-15 and KRISS are intelligent slave devices of the MicroVAX, performing the real time processing required in their respective environments. KRISS is available in four configurations: stereoscopic or monoscopic viewing with either 25 or 50 micron resolution, depending on the memory-size selected. The modular design of both hardware and software makes installation and/or upgrading easy and the implementation with other application software packages, such as MAPS200 or DTMCOL, very efficient.

A detailed description of the KRISS hardware and software concept may be found in the paper: "KRISS Kern Raster Image Superimposition System" by L. Cogan, D. Harbour and C. Peny (ISPRS Kyoto, July 1988).

- THE KERN CORRELATOR SYSTEM

Many repetitive, monotonous and tiresome photogrammetric tasks lend themselves to partial or even full automation. The Kern Correlator combines digital image processing techniques using standard hardware components (two CCD cameras, optics, a monitor, an image processing board and a set of transputers for faster computation) with the outstanding potential of the

DSR-15. The modular software is fully compatible with the Kern standard photogrammetric software. It takes over the orientation of the model, allows the automatic measurement of digital terrain models and the generation of orthophotos, and can even be used as a digital scanner. Thus, the versatility and economy of the DSR-15 are further enhanced.

More details on the Kern Correlator System, which marks another important step in digital photogrammetry, are described in the paper: "TOWARDS THE DIGITAL FUTURE", by Stefan Lutz (ISPRS Kyoto, July 1988).

- KERN DOTXS

This profiling program package allows the user to enter alignment specifications, such as tangents, circular arcs and transition spirals, to measure cross-sections by automatic profiling, to merge data for archiving and to plot the profiles on an XY graphic plotter. The horizontal alignment of the centre-line may be defined by keying-in parameters for each segment, by keying-in the data for each point of intersection, or by direct digitizing. In order to cope with terrain breaks, drainage and other topographical features which might be missed by even stationing intervals, special stations and skew sections may be defined during measurement. This package, which can be combined with PLOTR for the off-line plotting of MAPS-200 files and SCOPE or other terrain modelling packages, is available for all DSR models.

- KERN SPOT

The world-wide, urgent need for reliable topographic and thematic maps at scales of 1:50000 and smaller calls for ever more efficient and economic mapping solutions. Today, small-scale maps are increasingly produced by satellite photogrammetry, a recent technological development. In particular the French satellite "SPOT", launched in February 1986, transmits panchromatic and multispectral imagery of very high resolution (7.5, 10 or 20 metres, depending on the level of processing), which can efficiently be used for this purpose. The coverage of a single image is about 60km x 60km.

The software package "KERN SPOT", developed in collaboration with the University College London, permits stereo-restoration of satellite imagery in the DSR-12 and DSR-15 analytical plotters. The only hardware modification required is the simple exchange of the standard PDP-11/23 CPU in the plate-processor for such as the more powerful PDP-11/73. After the orientation of the satellite model, standard Kern photogrammetric software, like MAPS-200 or DTMCOL, can be used for stereo-plotting.

7.1 KERN INFOCAM

The DSR can be part of a network, such as the DEC Ethernet, which can contain a central data base. The Kern INFOCAM system offers a solution for the integration of photogrammetric data with the data base. It provides the necessary data structure and data manipulation capability, and the ability to both generate and read meta-files. Of course, INFOCAM may be used at the same time as a stand-alone station.

7.2 SOFTCOPY

On some models, a softcopy option is available as an alternative for producing on-line checkplots on drum-plotters or the GP1. The host processor is supplied with a graphics screen instead of a purely alphanumeric one; the digital map produced is sent to this device, where it can be checked and edited. The operator can toggle between the digital map and the alphanumeric displays and menus by a single keystroke.

8. CONCLUSION

The new DSR series of first order analytical plotters, used alone or integrated into larger systems, are efficient photogrammetric workstations. Their digital capacities can be selected to suit the actual requirements. Options based on the latest technologies are available to further enhance their versatility and economy. In the case of a computer change for the DSR, Kern designed the concept such that the operator uses the application software in exactly the same manner he did before.